

# TITAN

West Coast Ladders • 1-310-961-9559

**VISIT OUR  
WEBSITE!!**

[www.WestCoastLadders.com](http://www.WestCoastLadders.com)



All Products meet and/or exceed the  
OSHA &ANSI requirements!



**CALL TODAY!**

**1.310-961-9559**

# FIBERGLASS

## STEPLADDER 1000 SERIES

TYPE 1A EXTRA HEAVY DUTY | 300 LBS. DUTY RATING

- ★ Molded Boot - Prevents Fiberglass Splitting
- ★ Knee Braces on Top and Bottom on Both Sides of Ladder
- ★ Heavy Duty Hinge
- ★ Double Reinforced Bottom Step

Model	Size	Weight
1003	3'	14
1004	4'	17
1005	5'	20
1006	6'	23
1007	7'	26
1008	8'	30
1010	10'	43
1012	12'	52



# FIBERGLASS

## STEPLADDER 2000 SERIES

TYPE 1AA EXTRA HEAVY DUTY | 375 LBS. DUTY RATING

- ★ Double Reinforced Bottom Step
- ★ Molded Boot - Prevents Fiberglass Splitting
- ★ Knee Bracing on Every Step Front and Back
- ★ Heavy Duty Hinge

Model	Size	Weight
2004	4'	18
2005	5'	22
2006	6'	25
2008	8'	33
2010	10'	44
2012	12'	54

BEST



1

# FIBERGLASS

## DOUBLE STEPLADDER 3000 SERIES

TYPE 1A EXTRA HEAVY DUTY | 300 LBS. DUTY RATING

- ★ Molded Boot - Prevents Fiberglass Splitting
- ★ Inside Spreader Braces
- ★ Knee Braces on Top and Bottom of Both Sides of Ladder
- ★ Double Reinforced Bottom Step

Model	Size	Weight
3004	4'	21
3005	5'	24
3006	6'	29
3008	8'	38
3010	10'	57
3012	12'	69

BETTER



# FIBERGLASS

## DOUBLE STEPLADDER 4000 SERIES

TYPE 1AA EXTRA HEAVY DUTY | 375 LBS. DUTY RATING

- ★ Molded Boot - Prevents Fiberglass Splitting
- ★ Inside Spreader Braces
- ★ Knee Bracing on Every Step Front and Back
- ★ Double Reinforced Bottom Step

Model	Size	Weight
4004	4'	23
4005	5'	28
4006	6'	33
4008	8'	41
4010	10'	60
4012	12'	72
4014	14'	93
4016	16'	105

BEST



# ALUMINUM EXTENSION LADDER SERIES 7000 TITAN

TYPE 1A EXTRA HEAVY DUTY  
300 LBS. DUTY RATING

- ★ Outside Slide Guides
- ★ D-Rung Connection
- ★ Aluminum Rung Lock
- ★ Heavy Duty Steel Shoe

# FIBERGLASS EXTENSION LADDER SERIES 5000 TITAN

TYPE 1A EXTRA HEAVY DUTY  
300 LBS. DUTY RATING

- ★ Outside Slide Guides
- ★ D-Rung Connection
- ★ Aluminum Rung Lock
- ★ Heavy Duty Steel Shoe

# FIBERGLASS EXTENSION LADDER SERIES 9000 TITAN

TYPE 1AA EXTRA HEAVY DUTY  
375 LBS. DUTY RATING

- ★ Outside Slide Guides
- ★ Plate to Rail Connection
- ★ Aluminum Rung Lock
- ★ Heavy Duty Steel Shoe



Model	Size	Weight
7016	16'	32
7020	20'	39
7024	24'	46
7028	28'	53
7032	32'	60
7036	36'	77
7040	40'	84

Model	Size	Weight
5016	16'	36
5020	20'	44
5024	24'	52
5028	28'	59
5032	32'	72
5036	36'	82 *
5040	40'	96 *

\* 36 Ft. / 40 Ft.  
-250 lb. Capacity

Model	Size	Weight
9016	16'	39
9020	20'	48
9024	24'	56
9028	28'	64
9032	32'	74

2

# FIBERGLASS

## SINGLE LADDER **SERIES 6000 TITAN**

TYPE 1A EXTRA HEAVY DUTY | 300 LBS. DUTY RATING

- ★ D-Rung Connection
- ★ Heavy Duty Swivel Shoe



Model	Size	Weight
6008	8'	19
6010	10'	23
6012	12'	27
6014	14'	31
6016	16'	36
6018	18'	48
6020	20'	53

# FIBERGLASS

## EXTENSION LADDER **W/CABLE HOOK V-RUNG**

COMBINATION INSTALLED | 300 LBS. 1A RATED

- ★ D-Rung
- ★ Heavy Duty Swivel Shoe
- ★ Outside Slide Guides
- ★ Extruded Aluminum Rung Lock



\* Cable Hook V-Rung installed



Model	Size	Weight
5028CB	28'	63

# ALUMINUM

## WORK STAND **AWS SERIES**

TYPE 1A EXTRA HEAVY DUTY | 300 LBS. DUTY RATING  
27" WIDE



Model	Size	Weight
AWS2	27 1/2" x 2'	15
AWS3	27 1/2" x 3'	19
AWS4	27 1/2" x 4'	23

# FIBERGLASS

## STEP STOOL

300 LBS. DUTY RATING | 15" WIDE



Model	Size	Weight
3002	15" x 2'	12

# FIBERGLASS

## WORK STAND **FWS SERIES**

TYPE 1A EXTRA HEAVY DUTY | 300 LBS. DUTY RATING  
27" WIDE FOR A WIDER WORK SURFACE



Model	Size	Weight
FWS2	27 1/2" x 2'	17
FWS3	27 1/2" x 3'	24

# 16" Long Roof Bracket

- ★ Steel
- ★ Available in 3 various angles
- ★ Holds up to 6" wide plank

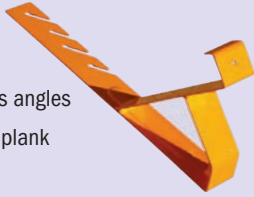

Model	Plank Size (In.)	Angle	WT.
346	2 x 6	45°	2
306	2 x 6	60°	2
356	2 x 6	90°	2

# Roof Hook

- ★ Quality roof hook, comes with wheel on back.
- ★ Attaches to any style Extension Ladder
- ★ Steel
- ★ Only need 1 per ladder



Model	Description	WT.
81DR	Roof Hook	7

# 19" Long Roof Bracket

- ★ Steel

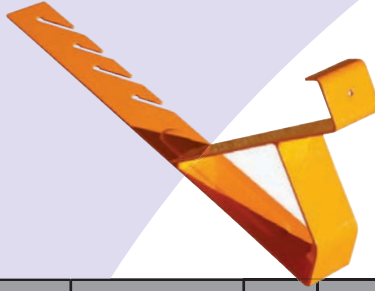

Model	Plank Size (In.)	Angle	WT.
RB2845	2 x 8	45°	3
RB21045	2 x 10	45°	3
RB2660	2 x 6	60°	3
RB2860	2 x 8	60°	3
RB21060	2 x 10	60°	3
RB2490	2 x 4	90°	3
RB2690	2 x 6	90°	3
RB2890	2 x 8	90°	3
RB21090	2 x 10	90°	3

# Adjustable Roof Bracket

- ★ Steel
- ★ Holds up to a 10" wide plank
- ★ Adjusts to 45°, 60° and 90° angles



Model	Description	WT.
400	Adjustable Roof Bracket	4

# Roof Guard Rail Hanger System

- ★ **Guard Rail Post Holder with Post**  
Use the Guard Rail Post Holder with Post to attach rails and secure the platforms for the work crew. This attaches to the Wall Brackets.
- ★ **Steel Over Plate Hanger**  
(orange color on diagram) This Steel over the Plate Hanger attaches over the Header of a Wall.
- ★ You can then attach a **Wall Bracket** to the Hanger.

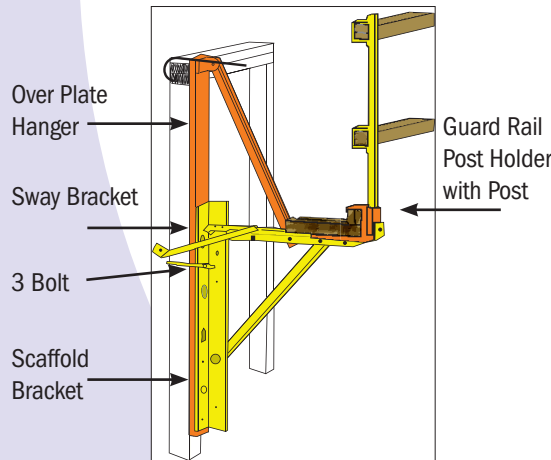

Model	Description	WT.
12020	Over Plate Hanger	8
12056	Guard Rail Post Holder with Post	6
12048	Scaffold Bracket 48"	20
12054	Corner Bracket	23

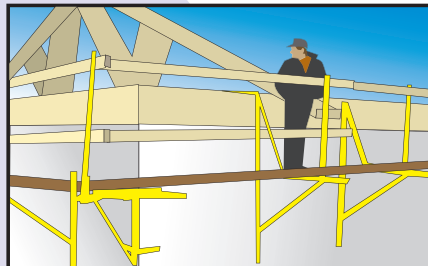

# Corner Bracket

- ★ Steel
- ★ 48" Long

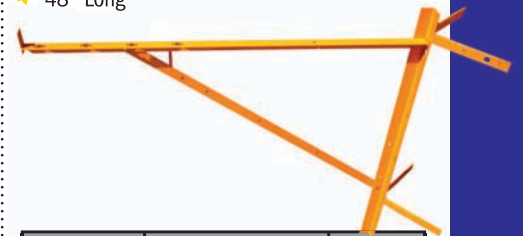

Model	Description	WT.
12054	Corner Bracket	23

# Wall Bracket

- ★ Steel
- ★ Perfect for working along a roof line.
- ★ 48" Wide
- ★ Affix these quality steel wall brackets to any structure and build a stable platform to work from.

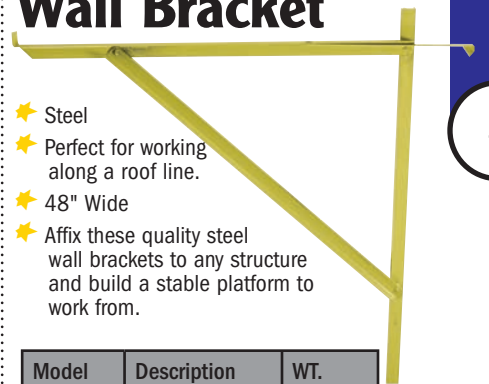

Model	Description	WT.
12048	Wall Bracket	20

# ALUMINUM PUMP JACK POLE SYSTEM

**NEW**

pump jack system

5

- The Aluminum Pump Jack Scaffold System is uniquely designed for you to work comfortably and safely at the exact height required.
- Easily transportable.
- Saves money and man power.
- 100% Compatible with all major brands.

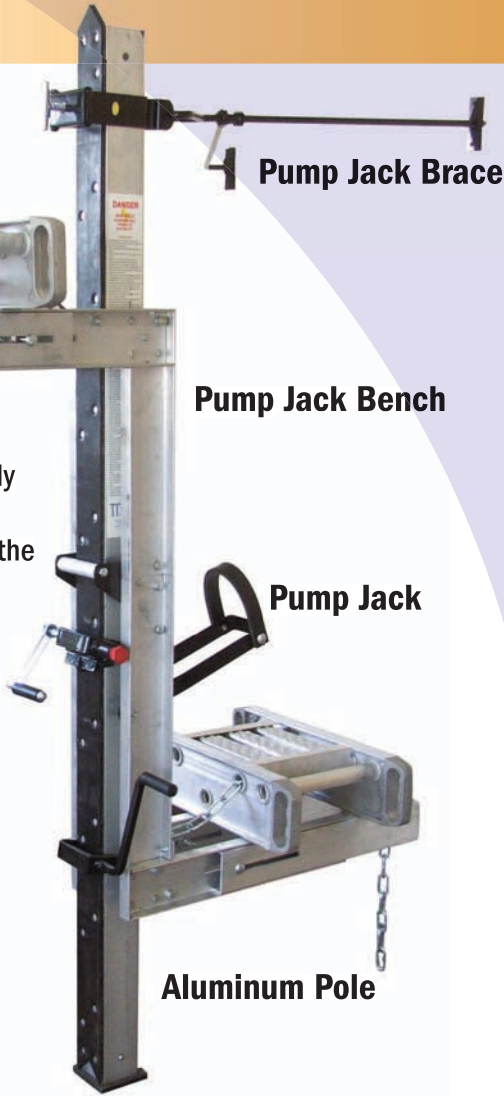

Pump Jack Brace

Pump Jack Bench

Pump Jack

Aluminum Pole

## PUMP JACK BRACE

Aluminum Pump Jack Brace



Model	Description	Weight
Al Brace	Pump Jack Brace	7



Model	Description	Wt.
Al Net	Safety Net	7

## PUMP JACK BENCH

Model	Description	Weight
Al Bench	Pump Jack Bench	20

## PUMP JACK

Aluminum Pump Jack



Model	Description	Weight
Al Jack	Aluminum Pump Jack	33

## ALUMINUM POLES

Includes Mud Cap

**TITAN**

**4 Sizes:**

6ft, 12ft, 18ft, or 24ft

Stackable-Aluminum poles can be quickly spliced and used to a 50' maximum shoulder working height (which meets OSHA requirements).

Model	Description	Weight
Pole-6	6'	13
Pole-12	12'	26
Pole-18	18'	39
Pole-24	24'	52

## 6' ALUMINUM INSERT

**TITAN**

Use when stacking aluminum poles.



Model	Description	Weight
Al Joint	6' Insert	9

# ALUMINUM PLANK

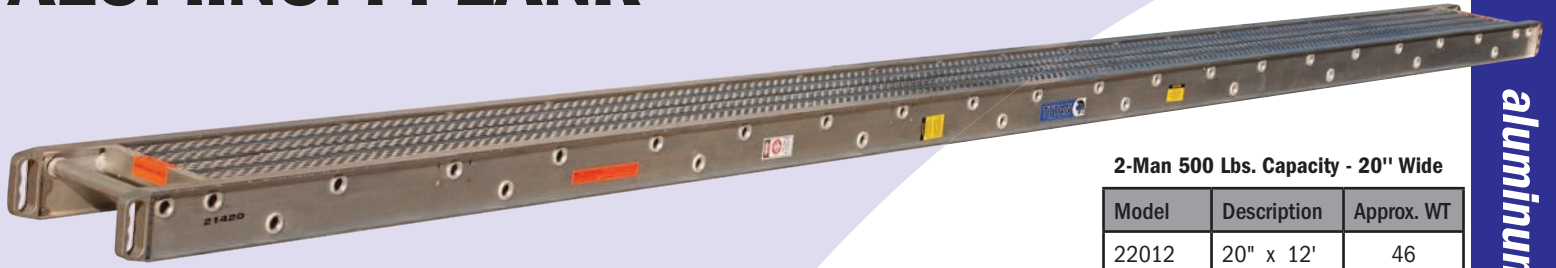

### 2-Man 500 Lbs. Capacity - 20" Wide

Model	Description	Approx. WT
22012	20" x 12'	46
22016	20" x 16'	66
22020	20" x 20'	94
22024	20" x 24'	112

### 2-Man 500 Lbs. Capacity - 12" Wide

Model	Description	Approx. WT
21212	12" x 12'	37
21216	12" x 16'	54
21220	12" x 20'	77
21224	12" x 24'	92

### 2-Man 500 Lbs. Capacity - 14" Wide

Model	Description	Approx. WT
21412	14" x 12'	38
21416	14" x 16'	57
21420	14" x 20'	82
21424	14" x 24'	98

### 2-Man 500 Lbs. Capacity - 24" Wide

Model	Description	Approx. WT
22412	24" x 12'	47
22416	24" x 16'	73
22420	24" x 20'	102
22424	24" x 24'	122

### 1-Man 250 Lbs. Capacity - 12" Wide

Model	Description	Approx. WT
11216	12" x 16'	47
11220	12" x 20'	61
11224	12" x 24'	72

## Aluminum Extension Plank

250 Lbs. Capacity  
14" Wide

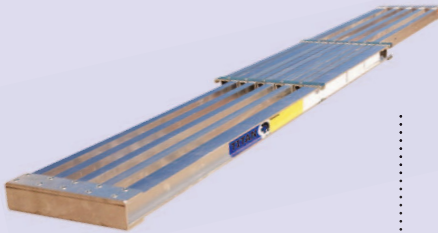

Model	Description	Approx. WT
EXT 6	14" x 6-9'	34
EXT 8	14" x 8-13'	45
EXT 10	14" x 10-17'	55

## LJSB

- ★ Short body ladder jacks extend to 2 rungs and will provide sturdy support.
- ★ Holds 12" and 14" plank
- ★ Sold in pairs



Model	Description	Approx. WT
LJSB	Short Jack	14

## LJLB

- ★ Long body ladder jacks will extend up to 3 rungs and provide sturdy support.
- ★ Holds 12" to 20" plank
- ★ Sold in pairs



Model	Description	Approx. WT
LJLB	Long Jack	18

# ALUMINUM RAIL SYSTEM

Fits into Aluminum Plank

INCLUDES- HAND RAIL, POSTS & TOE BOARD

Side Rail System 1-Side



\* Call for other sizes

### \* 1 - END

Model	Description	Weight (Lbs.)
E12	12"	3
E14	14"	4
E20	20"	5
E24	24"	6

Model	Description	Weight (Lbs.)
R16	16'	43
R20	20'	48
R24	24'	55

# 1 5/8" OUTSIDE DIAMETER TUBE 27 3/4" LOCK

## Model LF5Y - #6

1 section includes:

- (2) 5' x 5' Frames
- (2) Galvanized 7' Cross Braces
- (4) Stacking Pins

- ★ Outside diameter 1 5/8"
- ★ C - Lock
- ★ Coupling pins included
- ★ Yellow Powder Coated

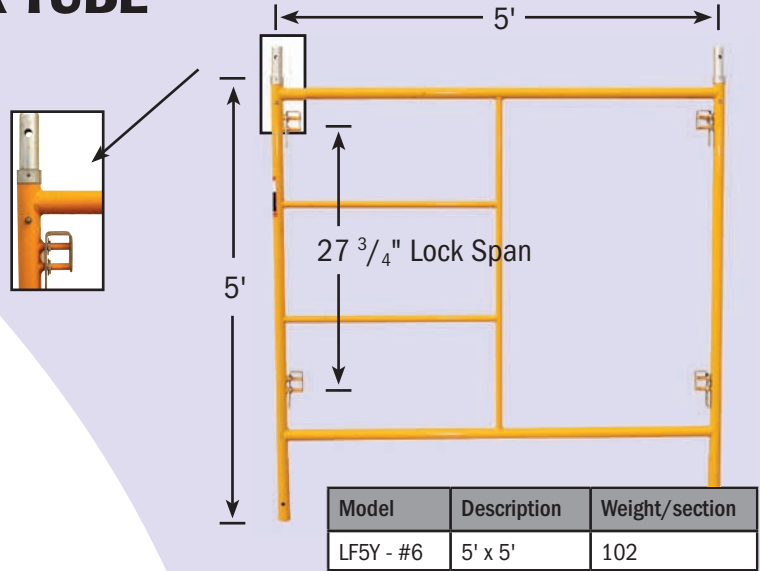

# 1 1/2" OUTSIDE DIAMETER TUBE 27 3/4" LOCK

## Model LF5Y - #SP

1 section includes:

- (2) 5' x 5' Frames,
- (2) Galvanized 7' Cross Braces
- (4) Stacking Pins

- ★ C - Lock
- ★ Outside diameter 1 1/2"
- ★ Powder Coat Yellow
- ★ Coupling pins included

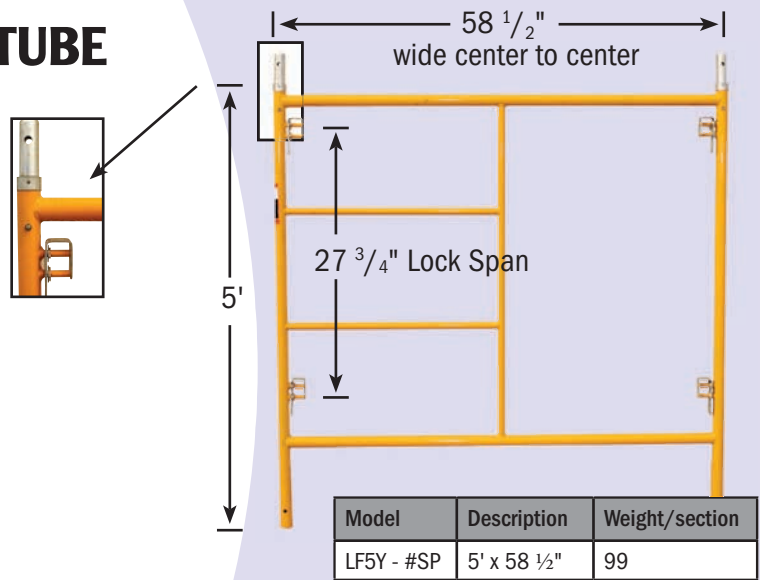

7

## FOLDING TRESTLES

- ★ 1000 lb. Capacity
- ★ All legs have foot plates
- ★ All Steel construction
- ★ 36" wide
- ★ Link Chain is welded to lower rung
- ★ Great for low rise applications
- ★ 2' or 3' Extensions complete unit

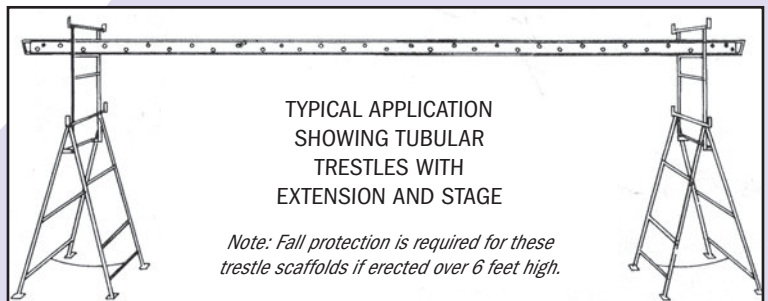
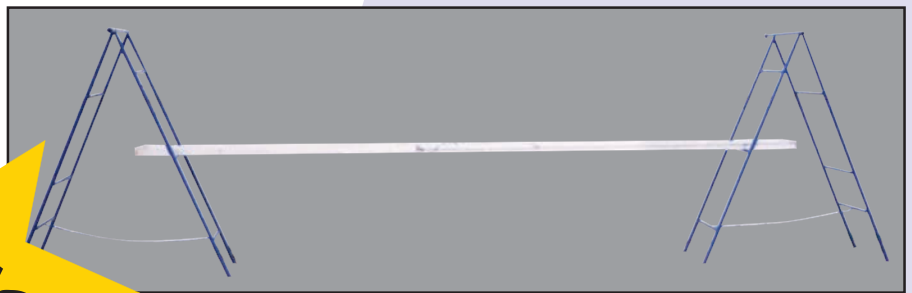
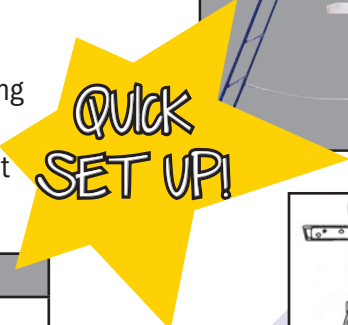

Model	Description	Weight
FT3	3' H.	22
FT4	4' H.	26
FT6	6' H.	38
EXT 2	2' L. Extension	12
EXT 3	3' L. Extension	14



# Premium Scaffold Package

## 1 11/16" OUTSIDE DIAMETER TUBE 48" LOCK SPAN

### Model # LF5Y

- 1 Section includes-
- (2) 5' x 5' Frames
- (2) 7' Galvanized Cross Braces
- (4) Stacking Pins

Tubing  
Outside Diameter 1 11/16"  
Coupling Pins included  
Yellow Powder Coated

**Most Popular!**

*This scaffold comes with the C locks, best and safest lock in the market.*

Model	Description	Weight/section
LF5Y	5' x 5'	102

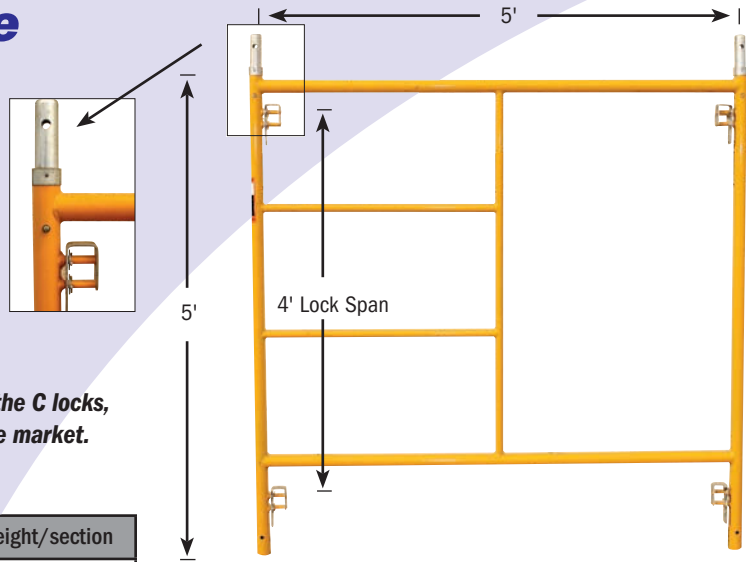

scaffold

8

## LF3Y

- 1 1 11/16" Tube size ladder frame
- 1 Section includes-
- (2) Frames
- (2) Galvanized 7' Cross Braces
- (4) Stacking Pins

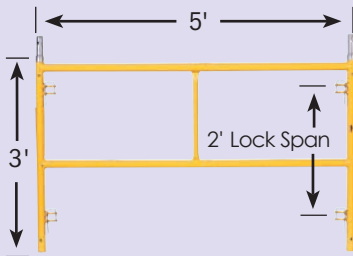

Model	Description	Weight/section
LF3Y	5' x 3'	78

## LF4Y

- 1 1 11/16" Tube size ladder frame
- 1 Section includes-
- (2) Frames
- (2) Galvanized 7' Cross Braces
- (4) Stacking Pins

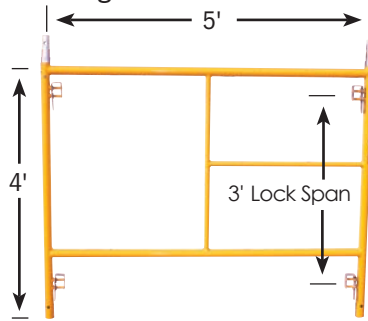

Model	Description	Weight/section
LF4Y	5' x 4'	90

## LF6Y

- 1 1 11/16" Tube size ladder frame
- 1 Section includes-
- (2) Frames
- (2) Galvanized 7' Cross Braces
- (4) Stacking Pins

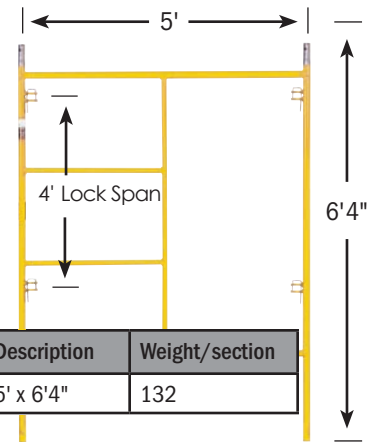

Model	Description	Weight/section
LF6Y	5' x 6'4"	132

## OE6YL

1 1 11/16" Tube size ladder frame  
Walk thru frame w/ 22" ladder

- 1 Section includes-
- (2) Frames
- (2) Galvanized 7' Cross Braces
- (4) Stacking Pins

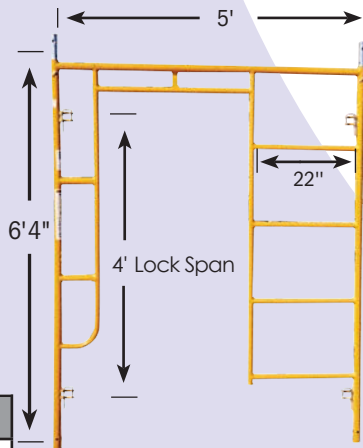

Model	Description	Weight/section
OE6YL	6'4" x 5' w/ 22" ladder	136

## OE6Y

1 1 11/16" Tube size ladder frame  
Designed as a walk thru frame.

- 1 Section includes-
- (2) Frames
- (2) Galvanized 7' Cross Braces
- (4) Stacking Pins

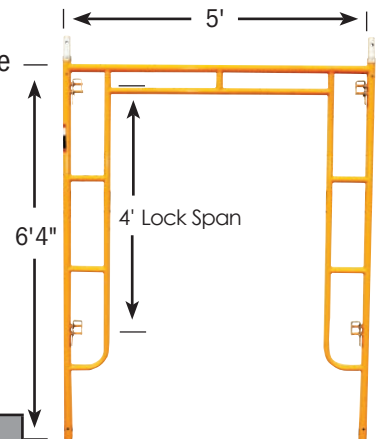

Model	Description	Weight/section
OE6Y	5' x 6'4"	132

# SCAFFOLD PACKAGE

## 1 5/8" TUBE SIZE

### LF5R

- 1 Section includes-
- (2) 5' x 5' Frames
- (2) 7' Cross Braces
- (4) Stacking Pins

Tubing  
 Outside Diameter 1 5/8"  
 Fast Lock  
 Coupling Pin w/ no collar  
 included Powder Coated Red

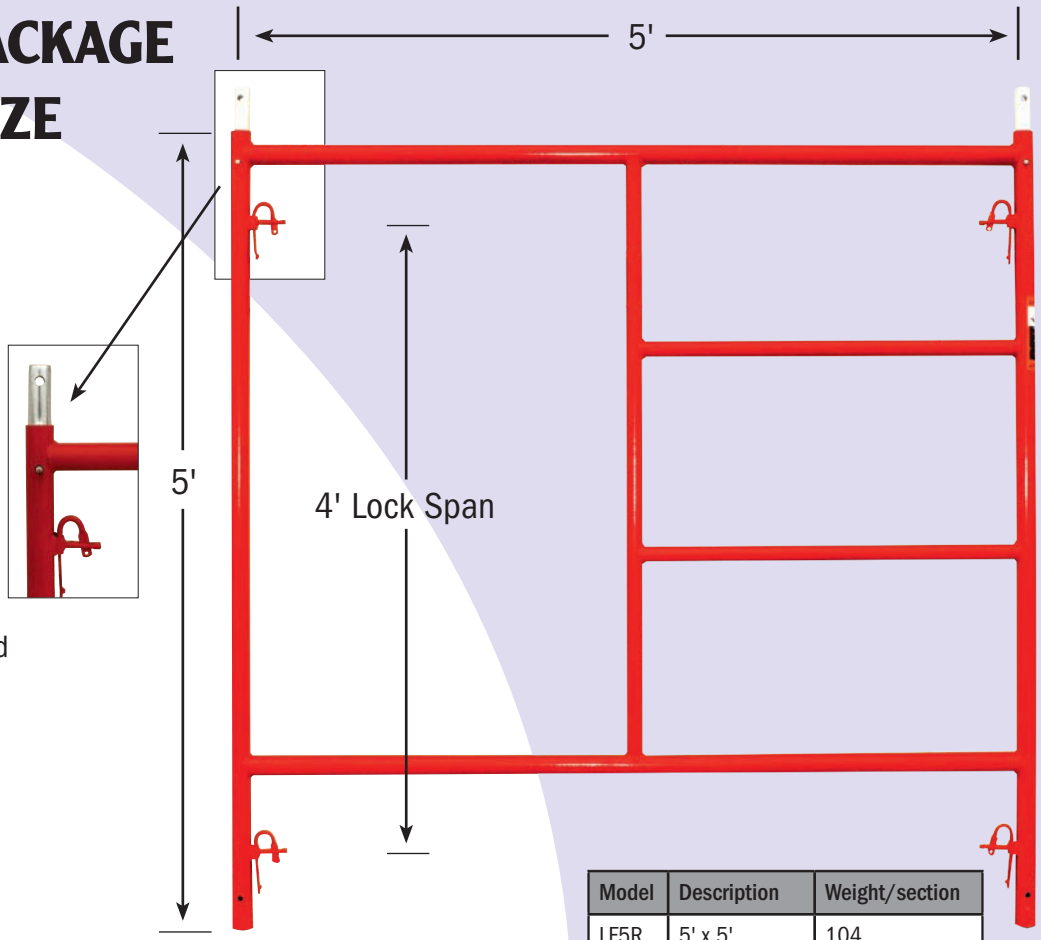

Model	Description	Weight/section
LF5R	5' x 5'	104

### LF3R

- Powder Coated Red
- 1 Section includes-
- (2) Frames
- (2) 7' Cross Braces
- (4) Stacking Pins

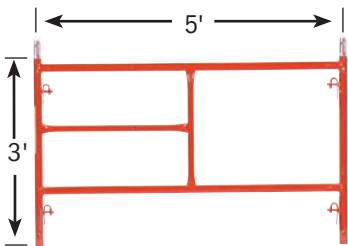

Model	Description	Weight/section
LF3R	5' x 3'	80

### LF6R

- Powder Coated Red
- 1 Section includes-
- (2) Frames
- (2) 7' Cross Braces
- (4) Stacking Pins

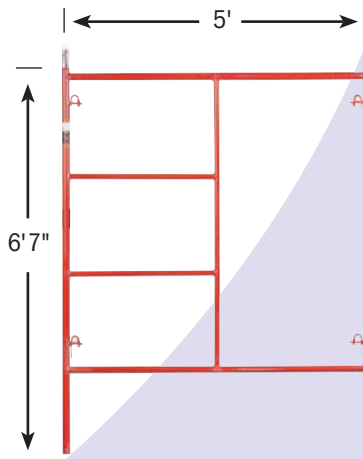

Model	Description	Weight/section
LF6R	5' x 6'7"	134

### OE6RHD

- Powder Coated Red
- 1 Section includes-
- (2) Frames
- (2) 7' Cross Braces
- (4) Stacking Pins

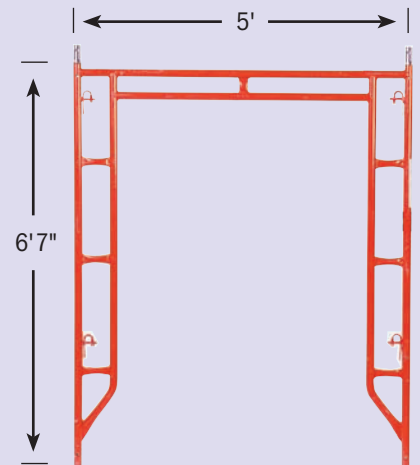

Model	Description	Weight/section
OE6RHD	5' x 6'7"	142

# LF3B

1 11/16" Outside Diameter Tube

- ★ B Style Scaffold
- ★ 5' x 3' Frame
- ★ Powder Coat Paint - Blue
- ★ Drop Locks
- ★ Stacking Pins included

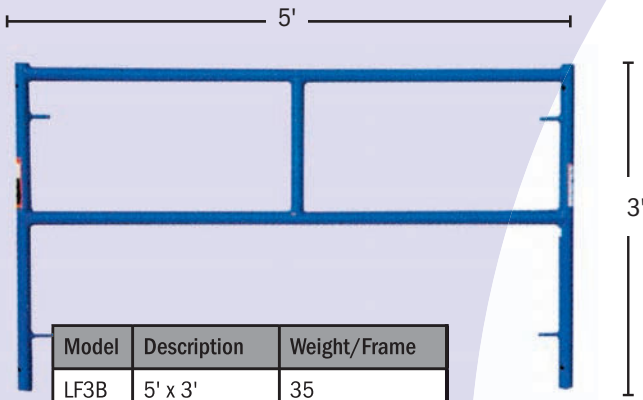

Model	Description	Weight/Frame
LF3B	5' x 3'	35

# LF5B

1 11/16" Outside Diameter Tube

- ★ B Style Scaffold
- ★ Powder Coat Paint - Blue
- ★ Stacking Pins included
- ★ Drop Locks
- ★ 5' x 5' Frame

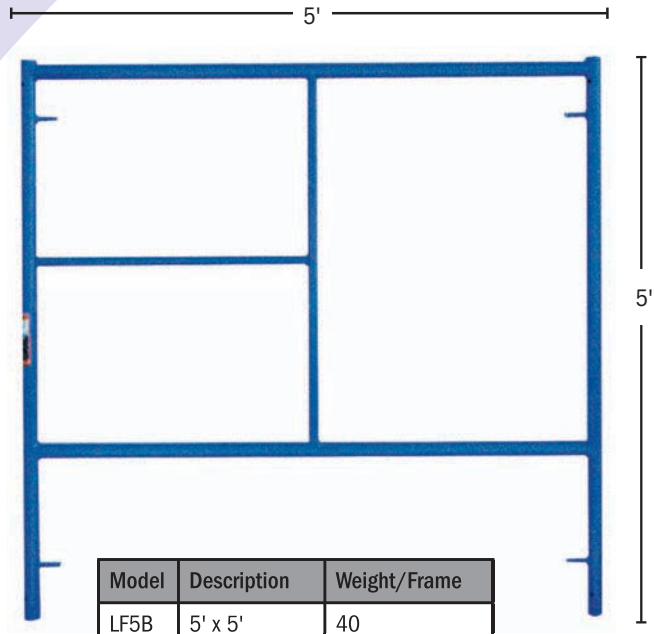

Model	Description	Weight/Frame
LF5B	5' x 5'	40

# LF6B

1 11/16" Outside Diameter Tube

- ★ B Style Scaffold
- ★ 5' x 6' 4" Single Ladder Frame
- ★ Powder Coat Paint - Blue
- ★ Drop Locks
- ★ Stacking Pins included

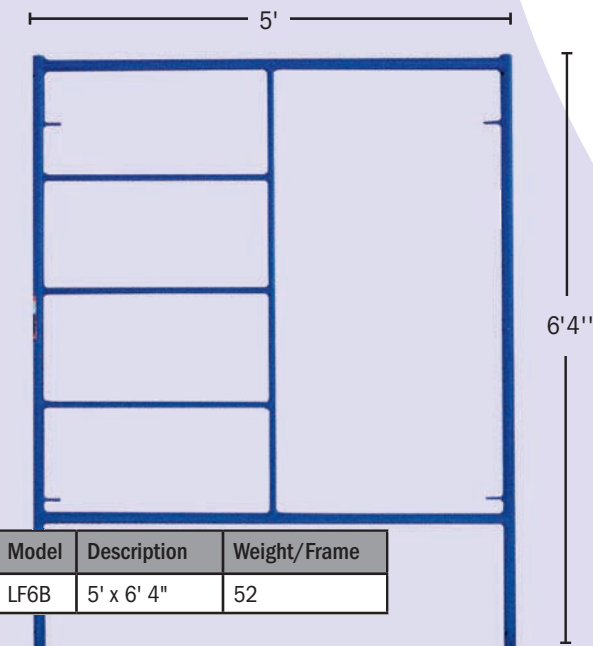

Model	Description	Weight/Frame
LF6B	5' x 6' 4"	52

# OE6V

1 11/16" Outside Diameter Tube

- ★ B Style Scaffold
- ★ 5' x 6' 4" Walk Thru Frame
- ★ Powder Coat Paint - Blue
- ★ Drop Locks
- ★ Stacking Pins included

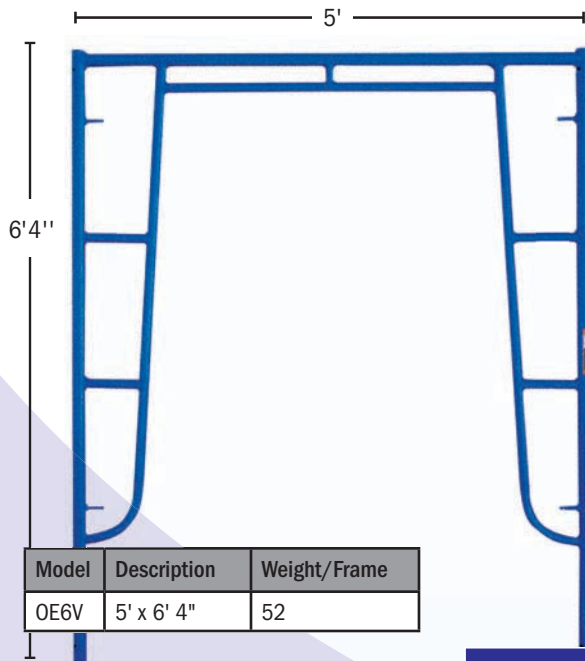

Model	Description	Weight/Frame
OE6V	5' x 6' 4"	52

# Multi Function Scaffold

- ★ 1000 Lb. Capacity
- ★ Powder coated yellow
- ★ Complete Unit Includes:  
(2) ends, (2) trusses,  
(1) plank, & (4) casters.



Model	Description	Weight
MFS	30" L. x 6' W. x 6' H.	152
MP-GR	Guardrail Unit	68
MP-OUT	Outriggers (set of 4)	32



Reinforced Handles



Heavy Duty 5" Locking Casters



Steel Reinforced Plywood



Spring Loaded Clip & Quality Powder Coated

## NARROW FRAME SCAFFOLD

- ★ Power coated red
- ★ Includes:  
(2) Frames  
(2) 7' Braces & (4) Stacking Pins

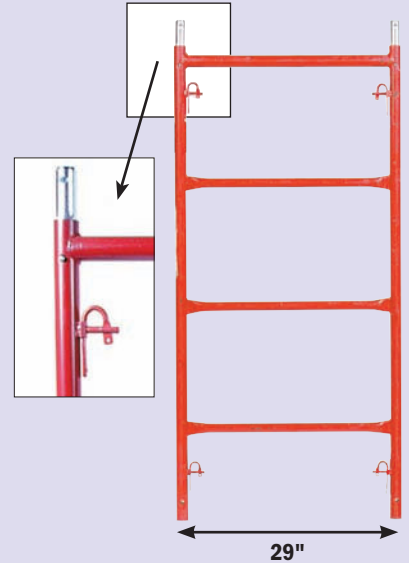

Model	Description	WT./section
NF3	29" X 3'	76
NF5	29" x 5'	94
NF6	29" x 6' 6"	100

## MORTAR BOARD STAND

- ★ Powder coated red
- ★ 20" X 30" Collapsible mortar stand
- ★ Steel Construction
- ★ Welded Chain

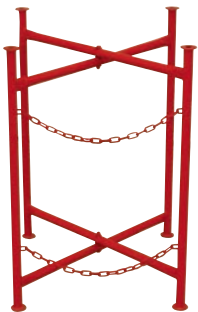

Model	Description	Weight
MBS	20" x 30"	12

## 4FT. MINI TOWER

- ★ Power coated yellow
- ★ Economical 4 Caster Unit
- ★ Includes:  
(4) 5" Casters & (2) Steel Planks
- ★ 500 lb. Capacity



Model	Description	Weight
SMINI	4' x 2' x 4'	58

## DRYWALL CART

- ★ Powder coated orange
- ★ 3000 Lbs. Capacity
- ★ Designed to haul full capacity loads with easy maneuverability and complete stability.
- ★ Includes:  
Heavy Duty 8" casters  
(2 Rigid & 2 Swivel Casters)
- ★ Also available in **ALL SWIVEL CASTERS**



Model	Description	Weight
DRY	Drywall Cart	90

## PEDESTAL SCAFFOLD FRAME

- ★ Designed for one-story brick work only
- ★ Height adjusts from 24" to 48".
- ★ Material shelf unit is conveniently located 20" above the walk board level.

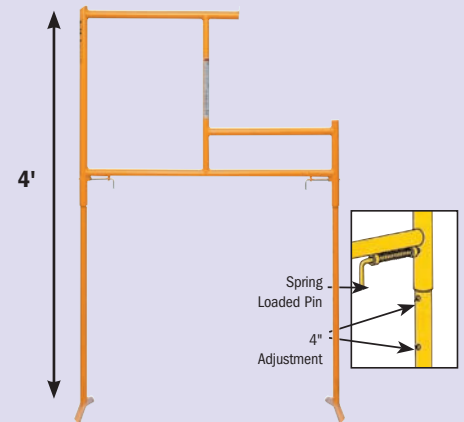

Model	Description	Weight
Ped	Pedestal Scaffold Frame	40

## ALUMINUM SCAFFOLD PLANK

- ★ All aluminum scaffold plank with 19" wide aluminum deck
- ★ 7' deck holds up to 75 Lbs. /Sq. ft. capacity
- ★ 10' deck holds up to 50 Lbs. /Sq. ft. capacity
- ★ Non slip surface



Model	Description	WT.
AP -7A	19" x 7' all aluminum	30
AP-10A	19" X 10' all aluminum	40

## ALUMINUM SCAFFOLD PLANK WITH PLYWOOD DECK

- ★ 19" wide, high quality plywood deck
- ★ 7' deck holds up to 75 Lbs./Sq. ft. capacity
- ★ 10' deck holds up to 50 Lbs./Sq. ft. capacity

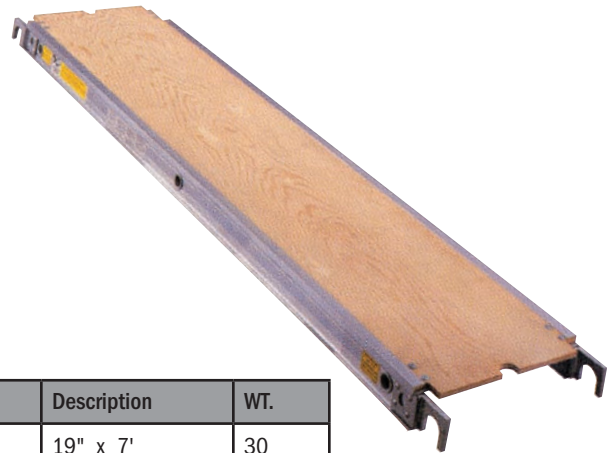

Model	Description	WT.
AP-7	19" x 7'	30
AP-10	19" X 10'	42

## ALUMINUM EXTENSION PLANK

- ★ 14" Wide
- ★ 250 Lbs. Capacity
- ★ Easy lock knob to lock plank in place

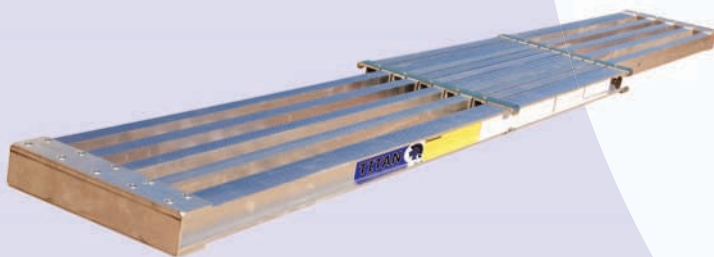

Model	Description	WT.
EXT6	14" W. x 6' - 9' L.	34
EXT8	14" W. x 8' - 13' L.	44
EXT10	14"W. x 10' - 17" L.	55

## LAMINATED SCAFFOLD GRADE PLANK

- ★ 10" Wide
- ★ OSHA grade laminated scaffold plank



**CALL FOR A QUOTE!**

Model	Description
PL-8LAM	2" x 10" x 8'
PL-12LAM	2" x 10" x 12'
PL-16LAM	2" x 10" x 16'

## SJ

- ★ Leveling jack with welded swivel base plate.
- ★ For use on uneven surface 1-3/8" diameter.
- ★ 24" High with 18" of adjustment.



Model	Description	WT.
SJ	Uneven Surface Leveling Jack	14

## ALBP

- ★ Leveling jack with base plate 1 3/8" diameter.
- ★ 24" high with 18" of adjustment.

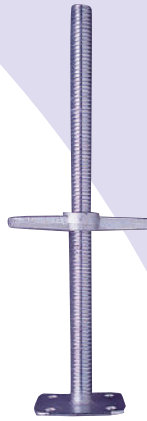

Model	Description	WT.
ALBP	Leveling Jack	14

## ALSO

- ★ Leveling jack with socket end for use with casters and base plates 1 3/8" diameter.
- ★ 24" High with 18" of adjustment



Model	Description	WT.
ALSO	Leveling Jack with Socket	14

## 8" Caster

- ★ 500 Lbs. Capacity
- ★ Locking mechanism for safe stationary use.



Model	Description	WT.
C8	8" Caster	12

## Rolling Tower Outrigger

- ★ Rolling tower outriggers are heavy duty stabilizers to go with industrial scaffolding. They are 27" H. x 29" W. The outriggers do not come with casters or feet.



Model	Description	WT.
OUT	27" x 29"	16

## Well Wheel

12 In. Diameter

- ★ Transfer equipment and materials up and down scaffolding with this simple and effective tool.
- ★ The well wheel and hoist arm add another effective dimension to your scaffolding structures.
- ★ All steel construction

Model	Description	WT.
WW	Well Wheel	15
HA	Hoist Arm	25

## Hoist Arm

75 Lbs. Capacity  
All Steel



## Toggle Pin



Model	Description	WT.
TP	Toggle Pin	25lbs./100

## Pig Tail Pin



Model	Description	WT.
GP	Pig Tail Pin	13lbs./100

## Base Plate

- ★ Interchangeable base adds more stability to your scaffold.
- ★ Compatible with ALSO leveling jack and requires pins.
- ★ Steel



Model	Description	WT.
BP	Base Plate	3

## Guard Rail System

- ★ Complete Guard Rail Systems, as pictured, includes the following:
  - (4) Guard Rail Posts,
  - (4) (GR-7) 7' Guard Rails,
  - (4) (GR-5) 5' Guard Rails
- \* Also available separately

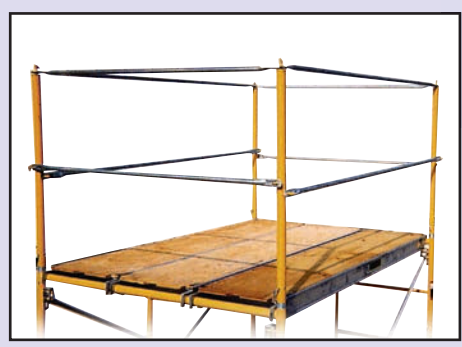

Model	Description	WT.
GRP	Guard Rail Posts	9
GR-5	5' Rail	4
GR-7	7' Rail	5
GR-10	10' Rail	11

## Tie Brace

- ★ Used for tying scaffold to wall
- ★ Tie Brace comes with Right Angle Clamp



Model	Weight
Tie Brace	12



## Diagonal Braces

- ★ Diagonal brace connects from corner to corner.
- ★ Keeps scaffold square.



Model	Description	WT.
D-7	5' x 7' Diagonal Brace	8

## Galvanized Cross Braces

Model	Description (Hole to Hole) (Ft. In.)	WT.
B72	7' 3 3/8"	12
B73	7' 7 3/8"	12
B727	7' 4 1 5/32"	12
B74	8' 3/4"	12
B102	10' 2 3/4"	17
B103	10' 5 5/16"	17
B104	10' 9 1/4"	17
B1027	10' 3 5/32"	17

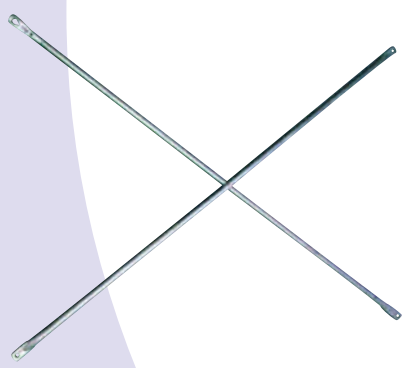

## Side Bracket Steel

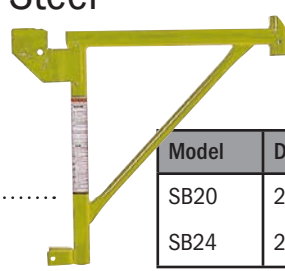

Model	Description	WT.
SB20	20"	9
SB24	24"	10

## Side Bracket Steel

- ★ Angle Iron

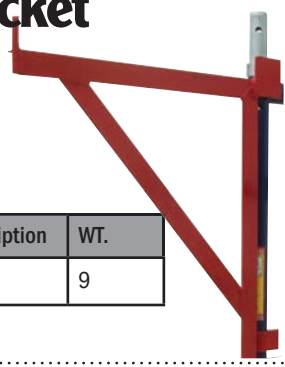

Model	Description	WT.
SB21A	20"	9

## 6' Access Ladder

- ★ Very Durable all Steel Access Ladder.
- ★ Brackets bolt directly to the scaffold.
- ★ Each ladder comes with 1 bracket.



Model	Description	WT.
ACC-6	6 ft.	25

## Steel Stair Units



Model	Description	WT.
ST7	7' long x 6'4" high steel stair unit. Comes with inside and outside handrail.	150

## Coupling Pins & Spring Retainer



Model	Description	WT.
CP-SW	Coupling pin with 1" collar	1
SCP-WA	Coupling no collar	1
SPR	Spring Retainer	.25

# TITAN

Ladders p. 1-3  
Roof & Wall Brackets p.4  
Pump Jack System p.5  
Aluminum Stages p.6  
Scaffold p. 7-11  
Scaffold Plank p. 12  
Scaffold Accessories p. 13-14

DISTRIBUTED BY: West Coast Ladders